

Ksoloti headers

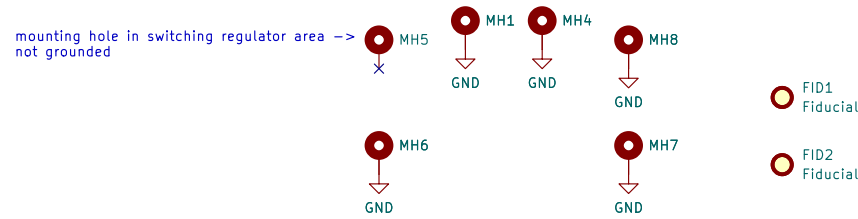

changelog		
[Redacted]		
File: changelog.kicad_sch		
Sheet: /		
File: ksoloti_gills_simple.kicad_sch		
Title:		
Size: A3	Date: 2023-10-23	Rev: v0.5
KiCad E.D.A. kicad (6.0.11)		Id: 1/9

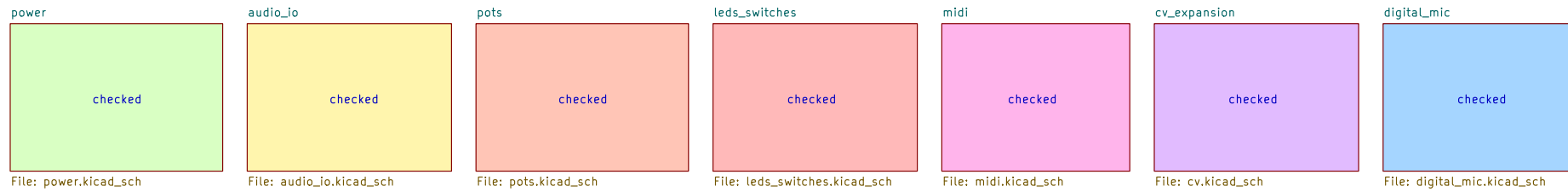
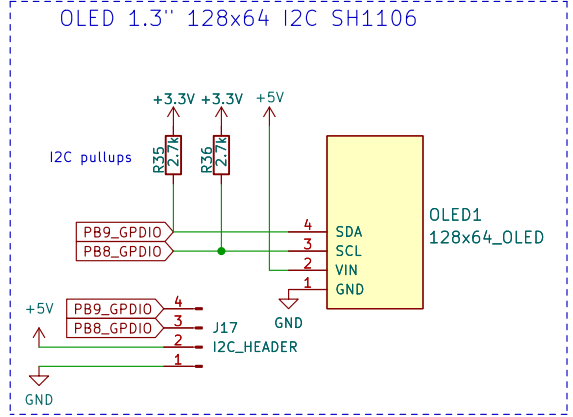
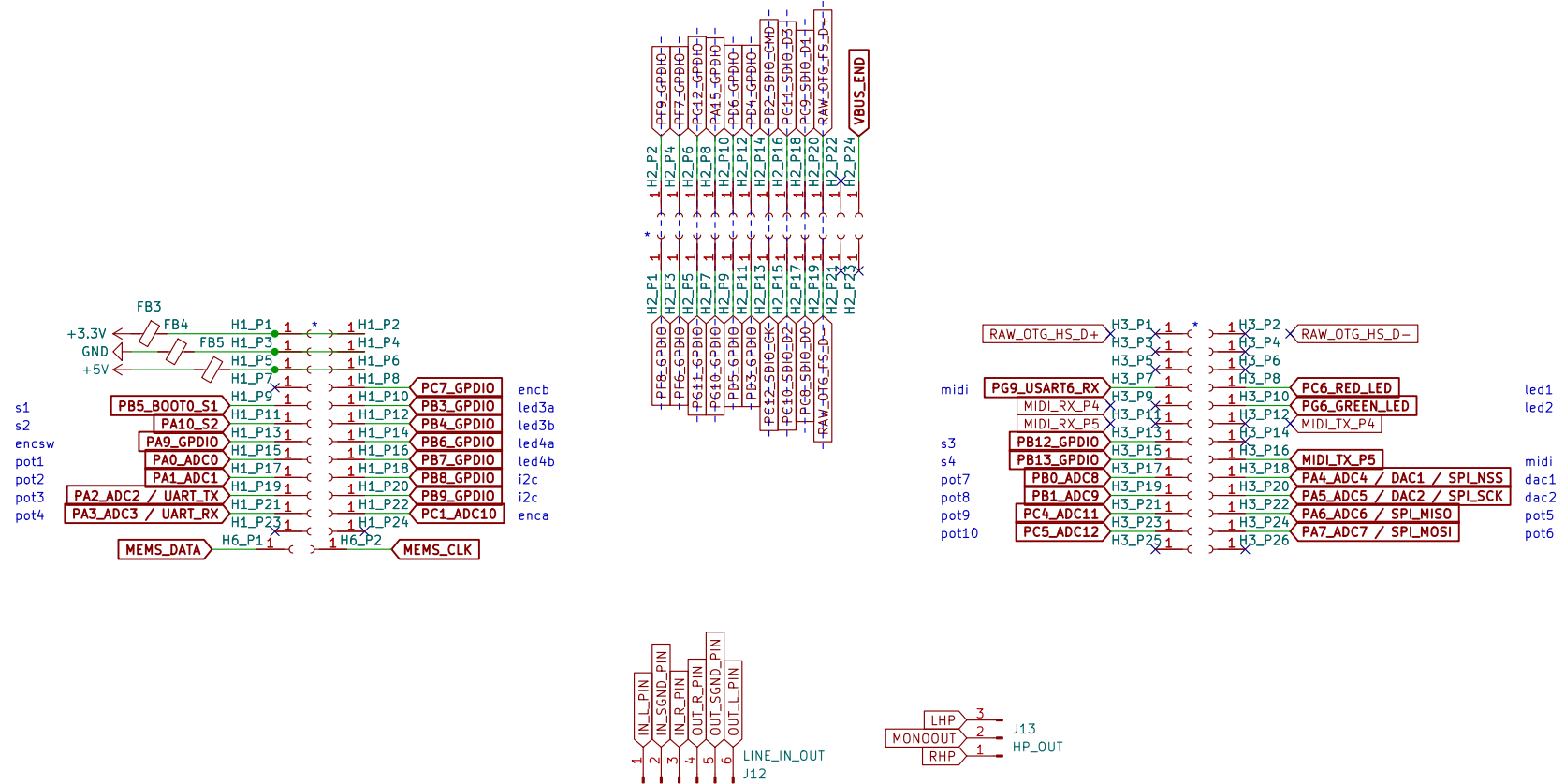
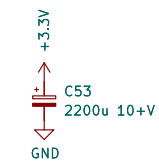
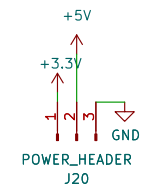
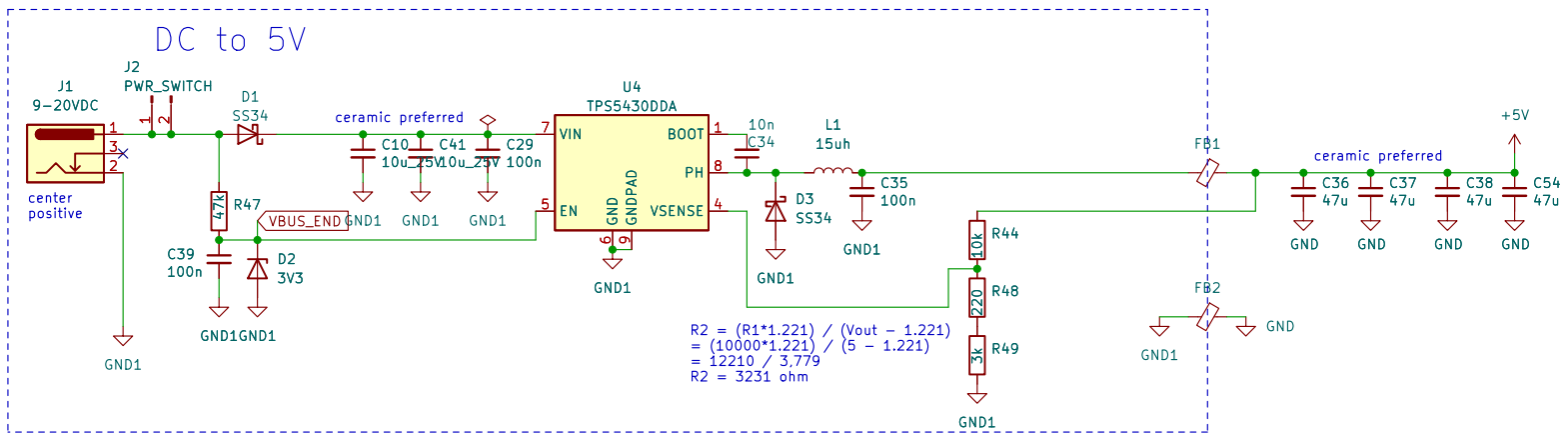

Sheet: /power/ File: power.kicad_sch	
Title:	
Size: A4	Date: 2023-10-23
KiCad E.D.A. kicad (6.0.11)	Rev: v0.5 Id: 2/9

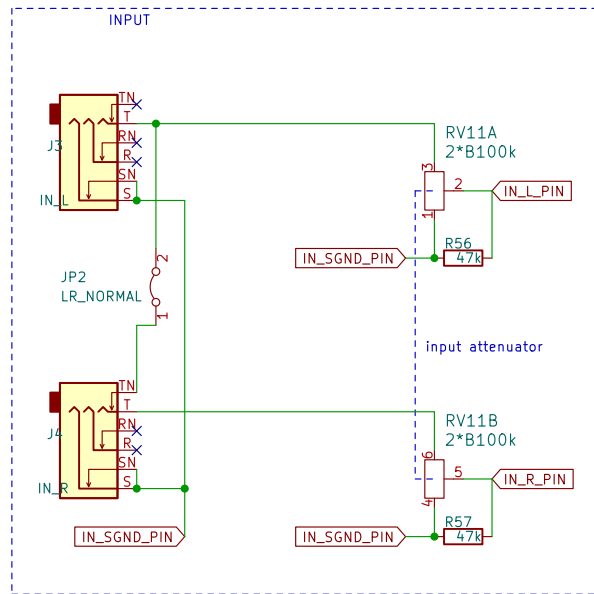

OPAMP BUFFERS REMOVED
DUE TO POSSIBLE NOISE

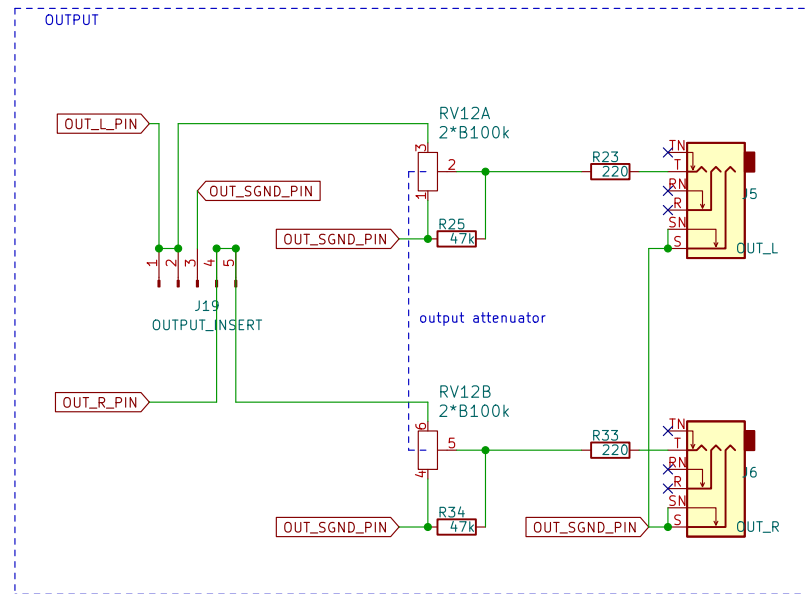

If installing a headphone volume pot,
cut bridges between pins 3&5 and 4&6!

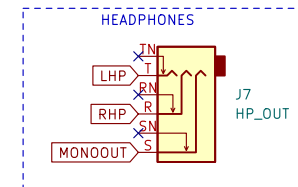
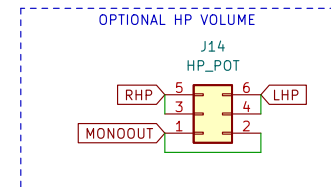

Pot "chassis"

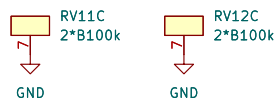

Sheet: /audio_io/
File: audio_io.kicad_sch

Title:

Size: A4 Date: 2023-10-23

KiCad E.D.A. kicad (6.0.11)

Rev: v0.5

Id: 3/9

RC lowpass cutoff ca. 72 Hz
full transient within ca. 10 ms

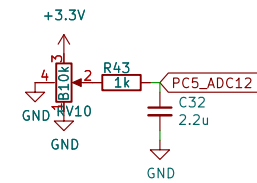
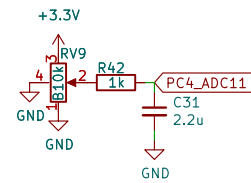
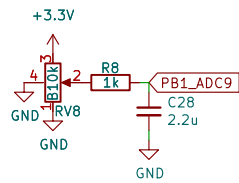
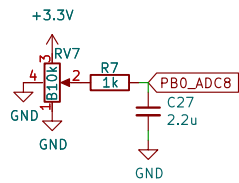
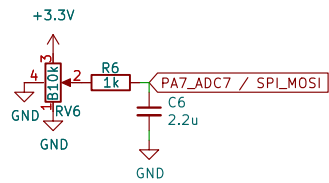
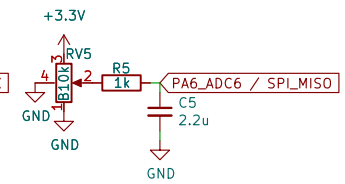
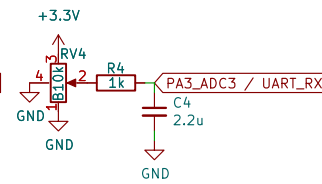
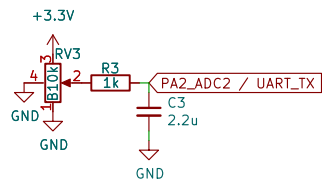
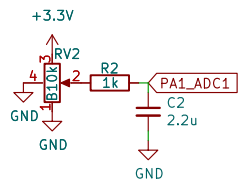
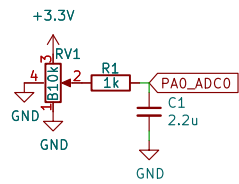

Sheet: /pots/
File: pots.kicad_sch

Title:

Size: A4 Date: 2024-04-12
KiCad E.D.A. kicad (6.0.11)

Rev: v0.5
Id: 4/9

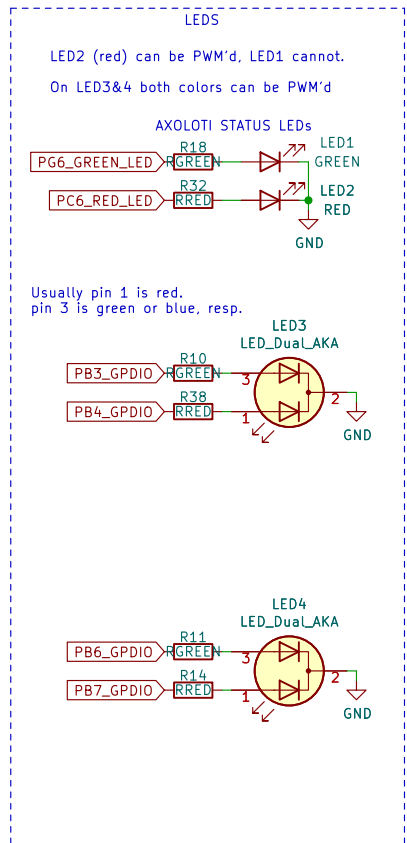
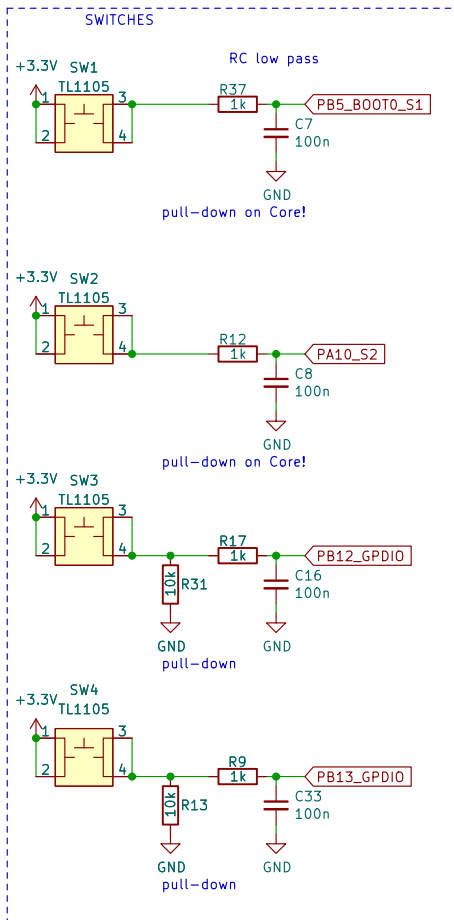
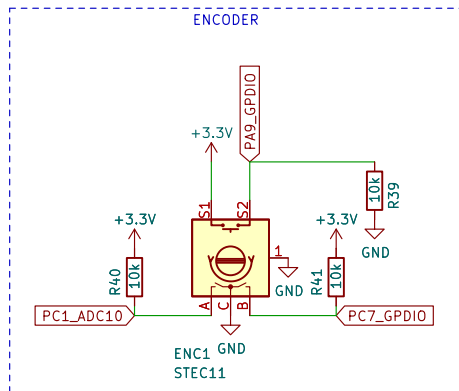

Sheet: /leds_switches/
File: leds_switches.kicad_sch

Title:

Size: A4 Date: 2023-10-23
KiCad E.D.A. kicad (6.0.11)

Rev: v0.5
Id: 5/9

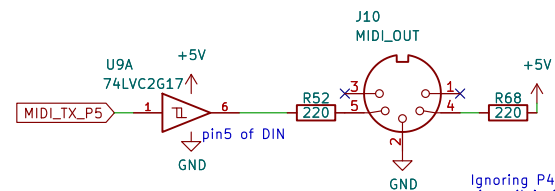
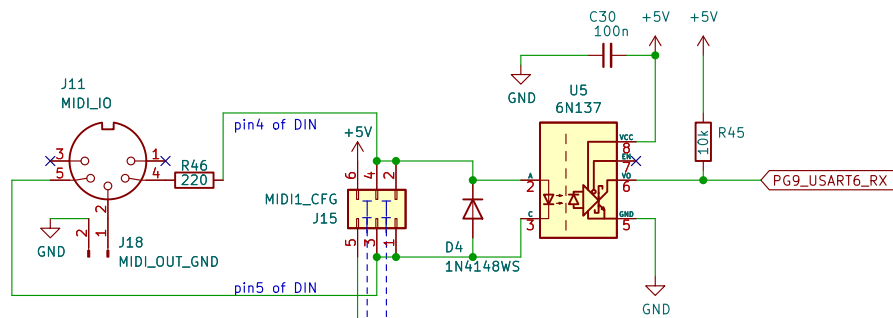

Ignoring P4 (MO4) signal from the Core since it is just a 220R pullup which is implemented locally here

SET AS: SECOND MIDI OUT (Bridge 3&5 and 4&6)
MIDI IN (Bridge 1&3 and 2&4. Bridged by default!)

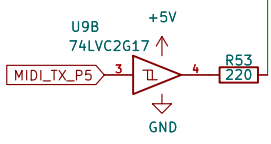

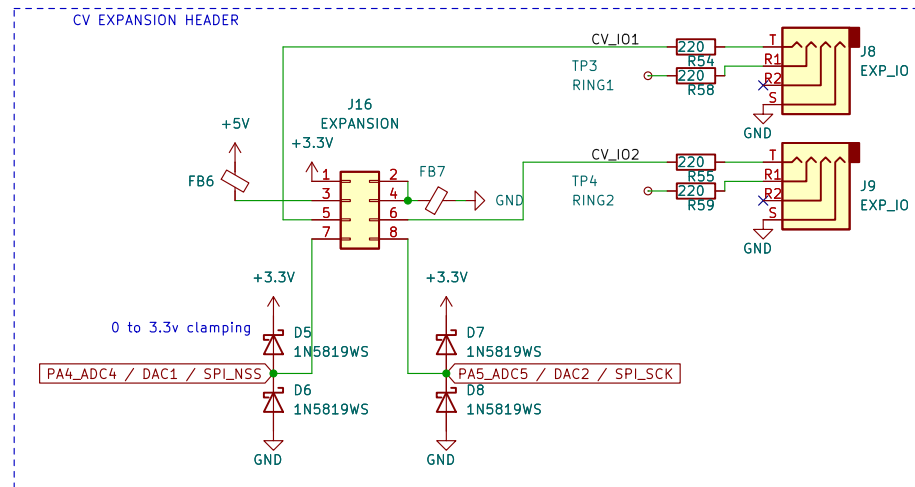

Connects to PA4, PA5 with overvoltage/overcurrent protection.
A CV Expander module is available to create modular synth control voltages.

You could also use PA4, PA5, as inputs and connect two external voltage sources, like foot switches, paddles, ribbon controllers, expression pedal, FSR...

In some cases you probably want to include 3.3V from J16.
You can solder a wire from 3.3V to the ring test point(s) labeled RINGx.
wire your device accordingly and use a stereo 3.5mm cable.

T = control signal
R = 3.3V
S = GND
[UNTESTED]

In case you need to run wires to the other side of the PCB ->  MH9 EMPTY_HOLE

Sheet: /cv_expansion/
File: cv.kicad_sch

Title:

Size: A4 Date: 2023-10-23
KiCad E.D.A. kicad (6.0.11)

Rev: v0.5
Id: 7/9

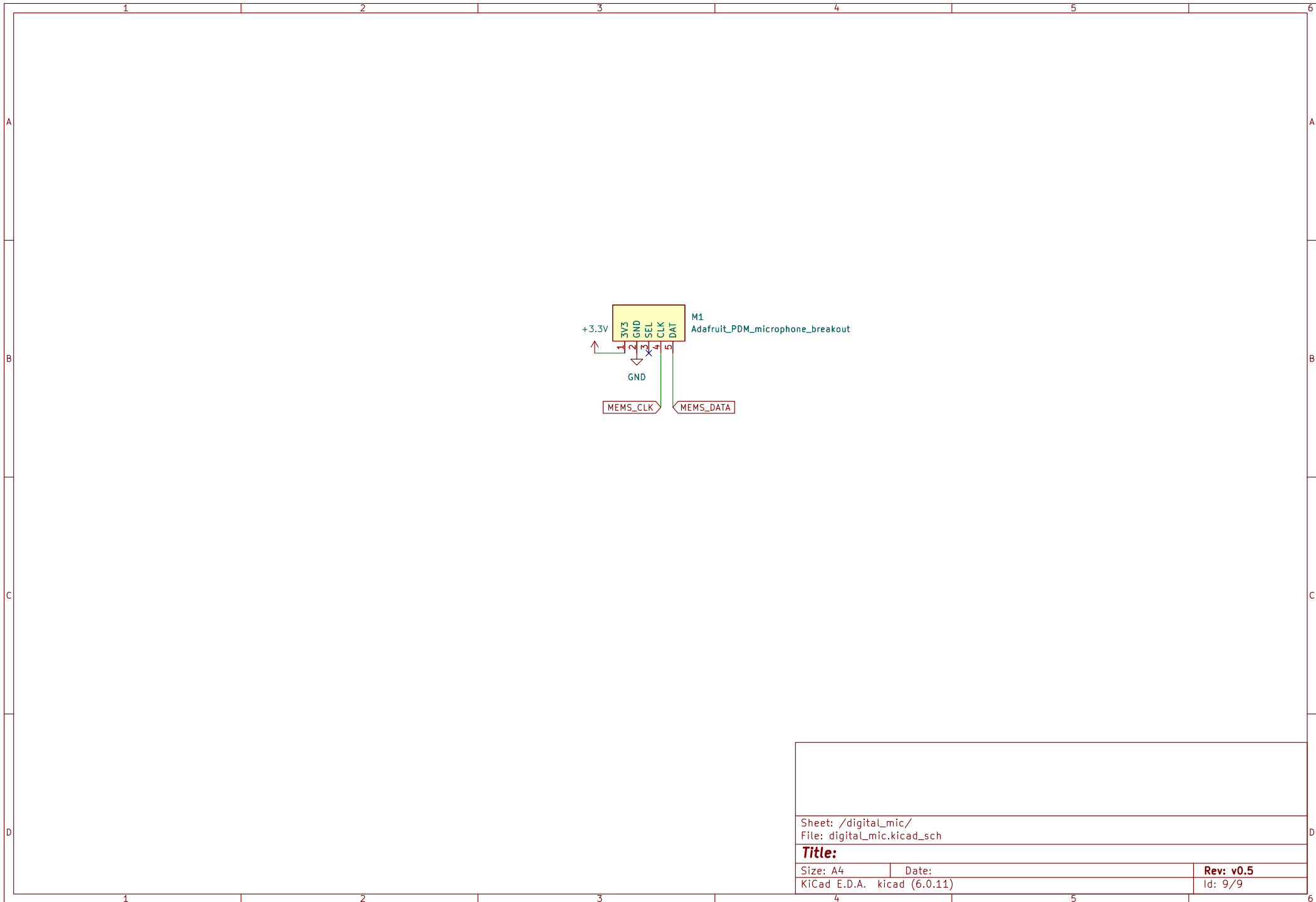

Sheet: /digital_mic/ File: digital_mic.kicad_sch		
Title:		
Size: A4	Date:	Rev: v0.5
KiCad E.D.A. kicad (6.0.11)		Id: 9/9

v0.1 done

- initial commit

v0.2 done

- Change OUT EXPANSION stereo 3.5mm jack to two mono jacks (so no adapter required), slimmer and more readily available PJ-320A footprint
- Add 3.3V to CV expansion header (if external pots etc. are to be connected)
- Add GND jumper to MIDI configuration header
- Adjust DIN MIDI socket footprint
- Bottom panel: additional M3 screw holes for more stability
- Fix swapped LED1 and LED2 labels (to conform with Axo tradition): LED1 green, LED2 red
- Swap colors on LED3 and LED4 (to conform with LED1 and LED2. Now the "color 1" of each dual-color LED is green/blue and "color2" is red)
- Increase LED resistors to 1k (green), 680R (red)
- Move encoder east by 2.5mm
- Add footprint for optional 1000uF cap on the 5V rail (if you encounter Core reboot when (un)plugging DC)
- Use 0805 resistors for LEDs and place in accessible spot

v0.3 done

- Move two mounting holes 2mm north
- Add SUM_IN_* pads for summing audio input signals. External cap and resistor required!
- Add OUTPUT_INSERT header. Can be set up as a send-receive before the output volume pot.
- Increase vertical board dimension. Adjust pot, buttons, LED vertical spacing
- Adjust gain of U7 (optional radio module amp)

v0.4 done

- Reroute some traces that were at risk of touching potentiometer chassis.
- Use NRJ6HF footprints for Line I/O Jacks instead of NRJ4HF.
- Move optional HP pot header north by 5mm.
- Tweak case dimensions, thicker silkscreen for white case option.

v0.5 done – production

- Add footprint for Adafruit PDM mic and a mic hole in the panel.
- Remove additional I2C header (avoid I2C lines running across the board), add generic power header.
- Improve DC power filtering, power and ground "entering" and "leaving" Core at only one location.
- Simplified audio signal path, doing away with the opamp buffers. Confine audio path to the 6-pin line in/out header coming from the Core.
- Edit "output insert" header to now include SGND pin.

Sheet: /changelog/
File: changelog.kicad_sch

Title:

Size: A4 Date: 2023-10-23

KiCad E.D.A. kicad (6.0.11)

Rev: v0.5

Id: 10/9